

ARTIKELNUMMER

WSA3025150	WSA6050305
WSA3025210	WSA6060210
WSA3030150	WSA6060300
WSA3030210	WSA6060400
WSA3040150	WSA6080300
WSA3525150	WSA6080302
WSA4030150	WSA7050210
WSA4030210	WSA7050260
WSA4040210	WSA8040300
WSA4050210	WSA8060210
WSA4060210	WSA8060211
WSA5030210	WSA8060260
WSA5040150	WSA8060300
WSA5040210	WSA8060305
WSA5040260	WSA8060400
WSA5040300	WSA8080210
WSA5050210	WSA8080300
WSA5050300	WSA1006260
WSA6040150	WSA1006300
WSA6040210	WSA1006409
WSA6040211	WSA1008260
WSA6040260	WSA1008300
WSA6040300	WSA1008409
WSA6050150	WSA1206300
WSA6050210	WSA1206409
WSA6050260	WSA1208300
WSA6050300	-

Dieses Produkt ist ein Leergehäuse für Niederspannungs-Schaltgerätee Anwendungen mit einer maximalen Nennspannung von 1000V AC oder 1500V DC für den Innenbereich

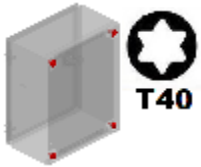



MONTAGE VON SCHRAUBEN UND DICHTUNGEN

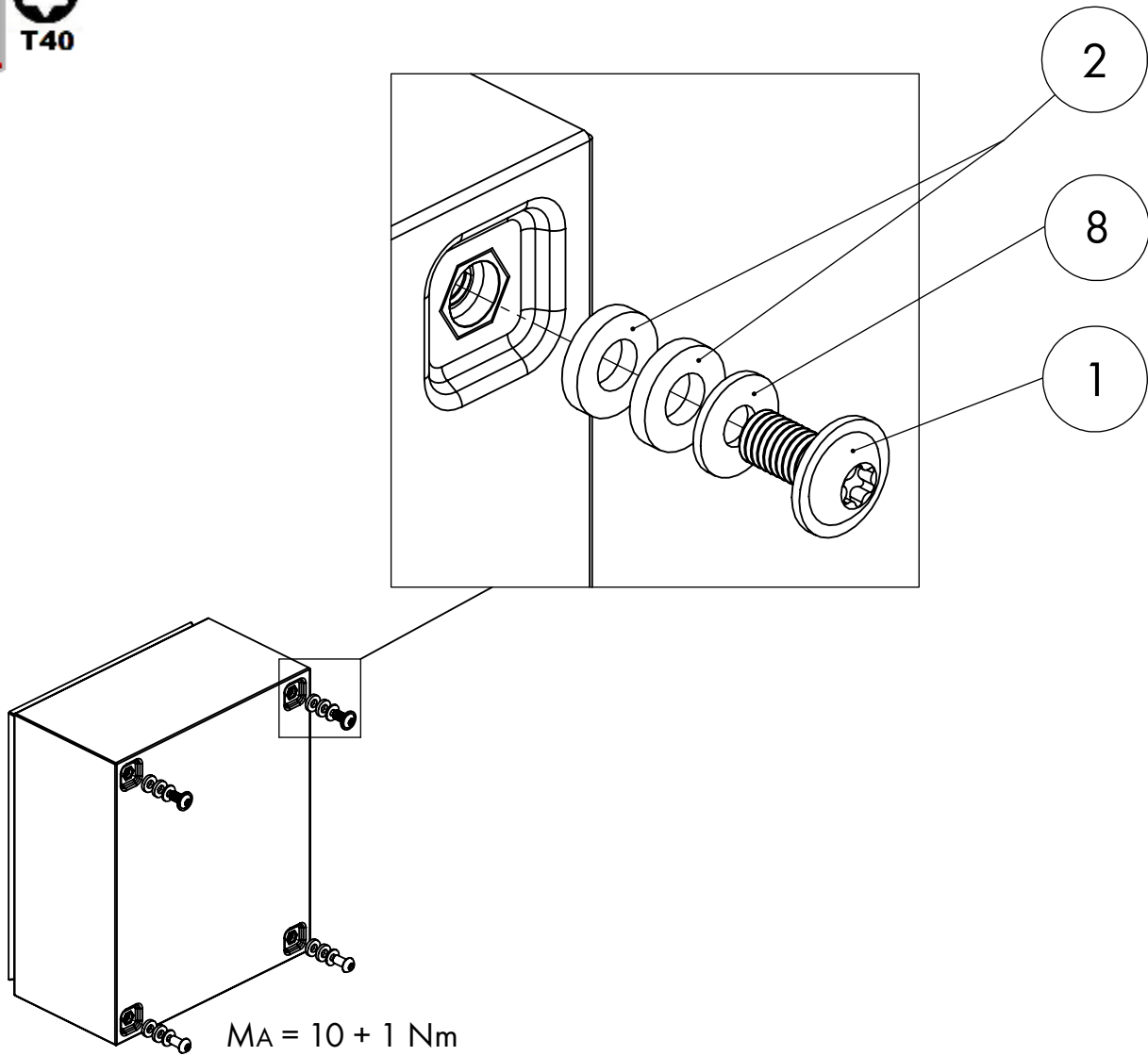

LIEFERUMFANG

Nr.	Stk.	Nr.	Stk.
1	4	7	1
2	8	8	5
3	E: 2 Z: 4	9	E: 3 Z: 5
4	E: 2 Z: 4	10	E: 1 Z: 2
5	1	11	1
6	**		

E=Eintürig

Z=Zweitürig

**=Die Anzahl der Teile ändert sich entsprechend der Gehäusegröße

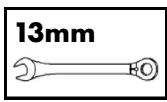
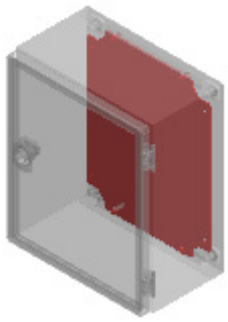

MONTAGEPLATTENBEFESTIGUNG

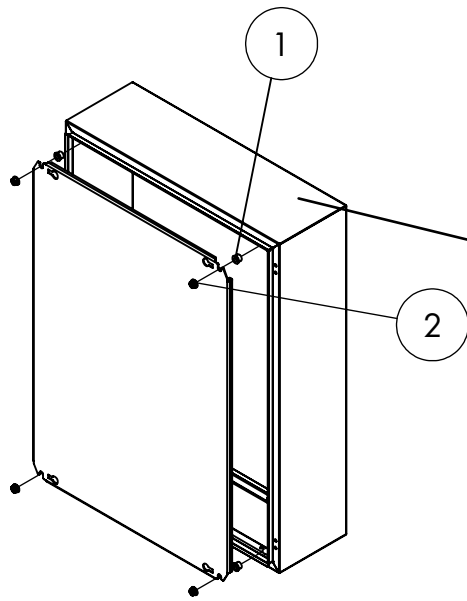

MA = 8 + 1 Nm

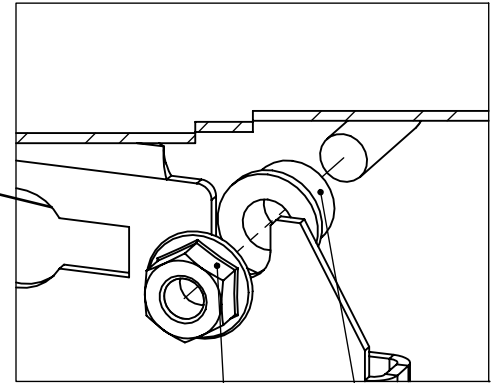

Ab Höhe 1000mm

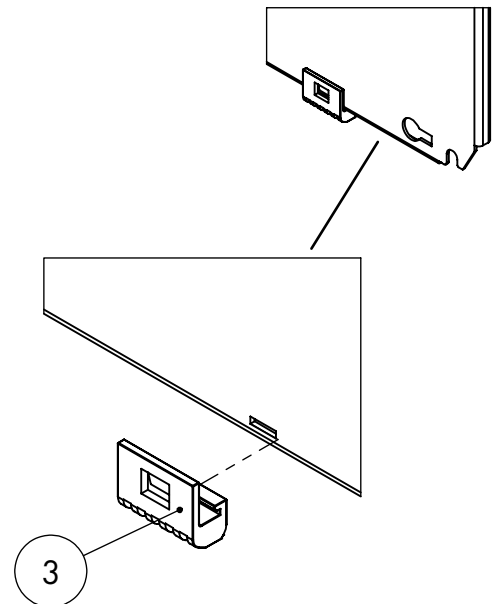
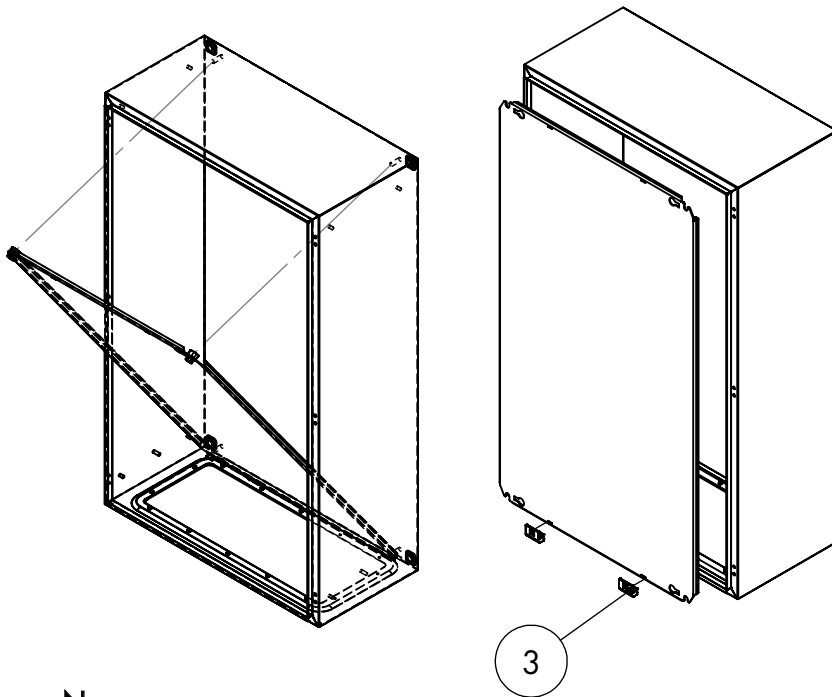

Nr.		
1		M8x11mm
2		M8
3		Montageplattenhalterung



FLANSCHPLATTEN MONTAGE

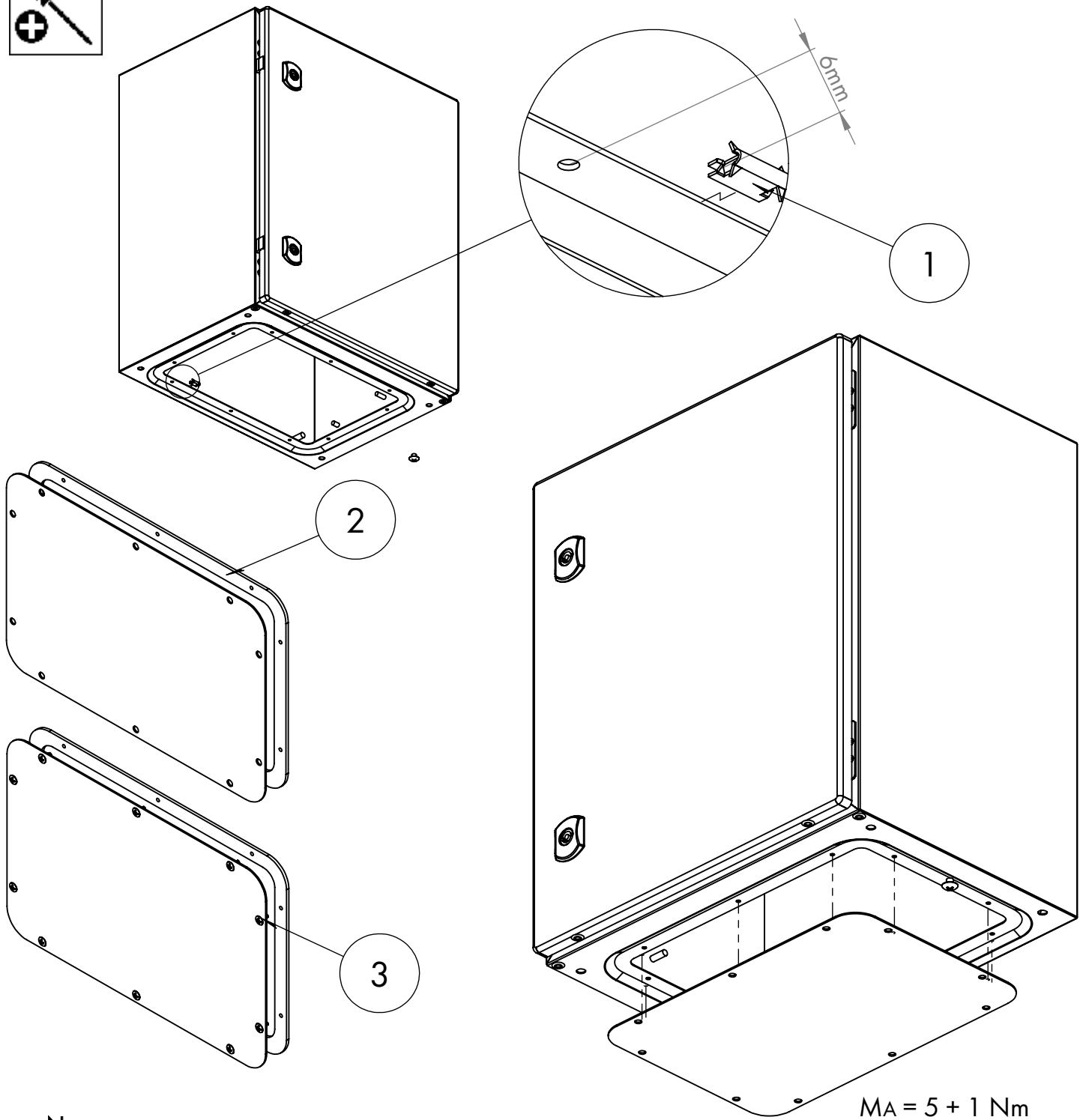

MA = 5 + 1 Nm

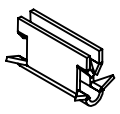
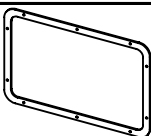
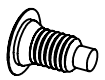
Nr.		
1		Erdungskralle
2		Dichtung
3		M4.8x9.5mm

FLANSCHPLATTEN MONTAGE

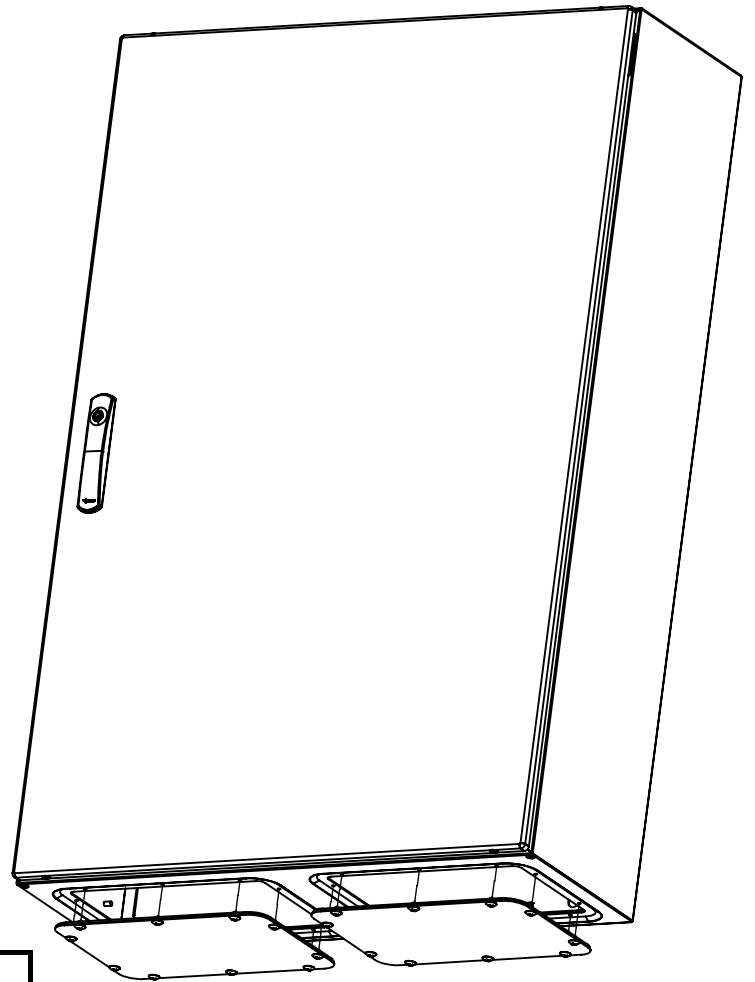
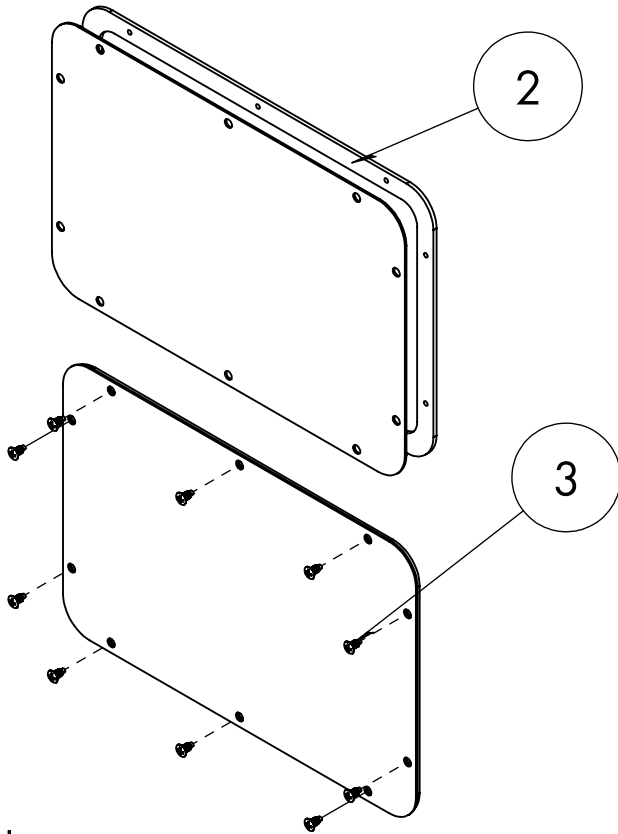
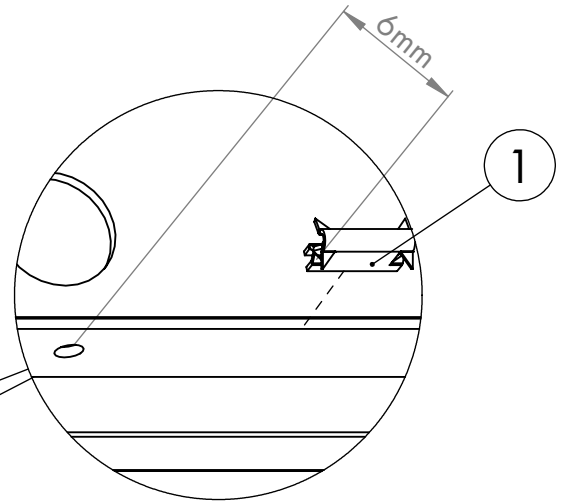
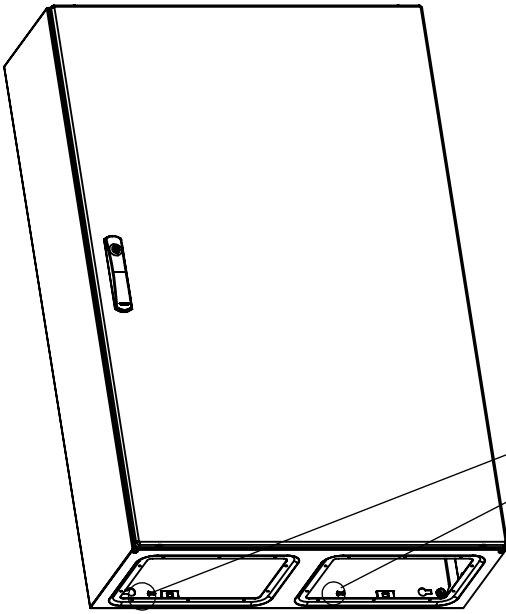

MA = 5 + 1 Nm

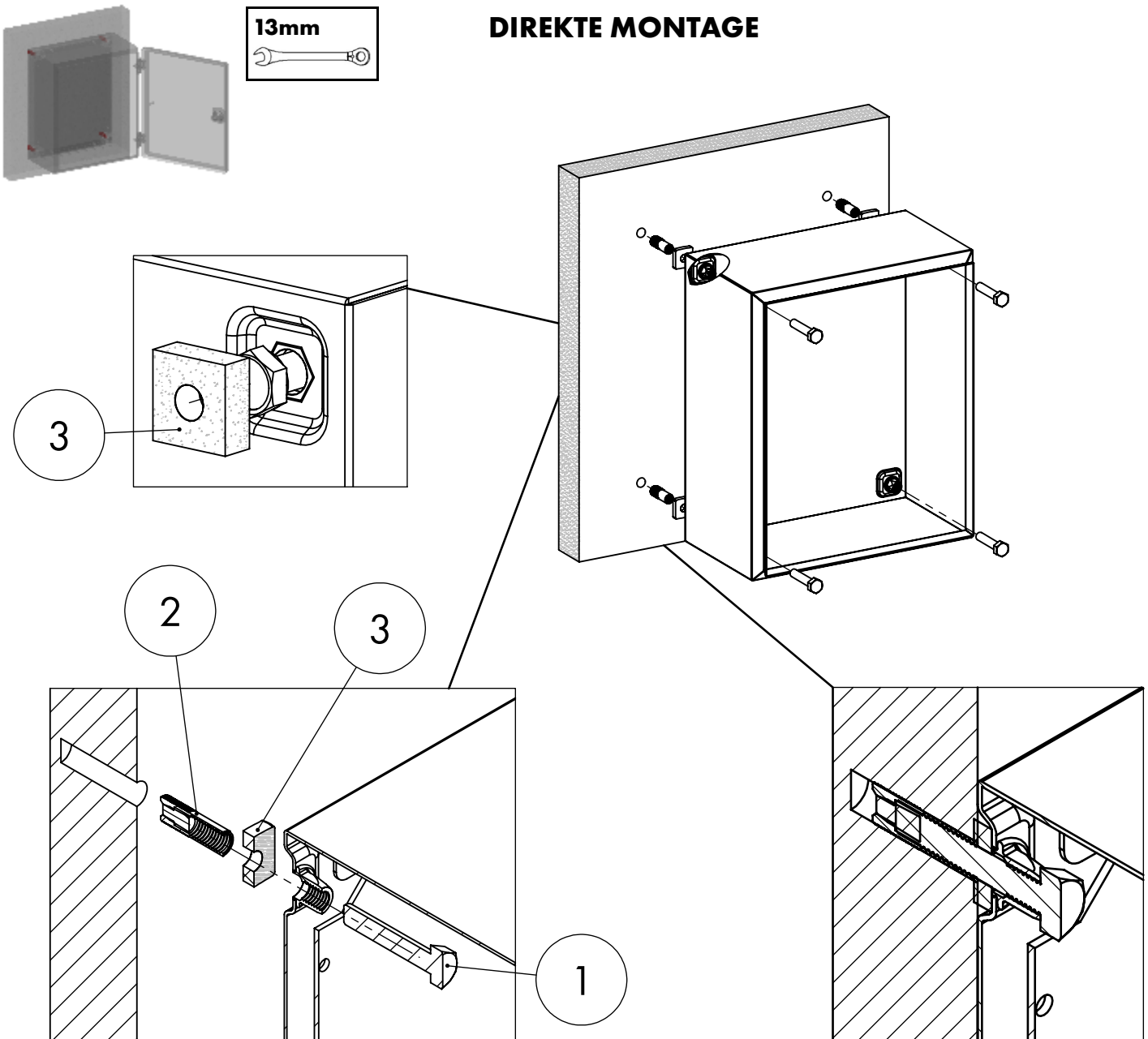

Nr.		
1		Erdungskralle
2		Dichtung
3		M4.8x9.5mm

DIREKTE MONTAGE

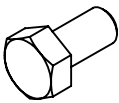

MA = 10 + 1 Nm

i **ERFORDERLICHE TEILE (Nicht im Lieferumfang enthalten!)**

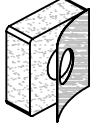

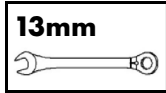
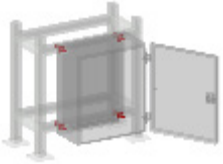
Nr.			Stk.
1		M8	4
2		Stahldübel M8	4
3		Selbstklebende Dichtung	4

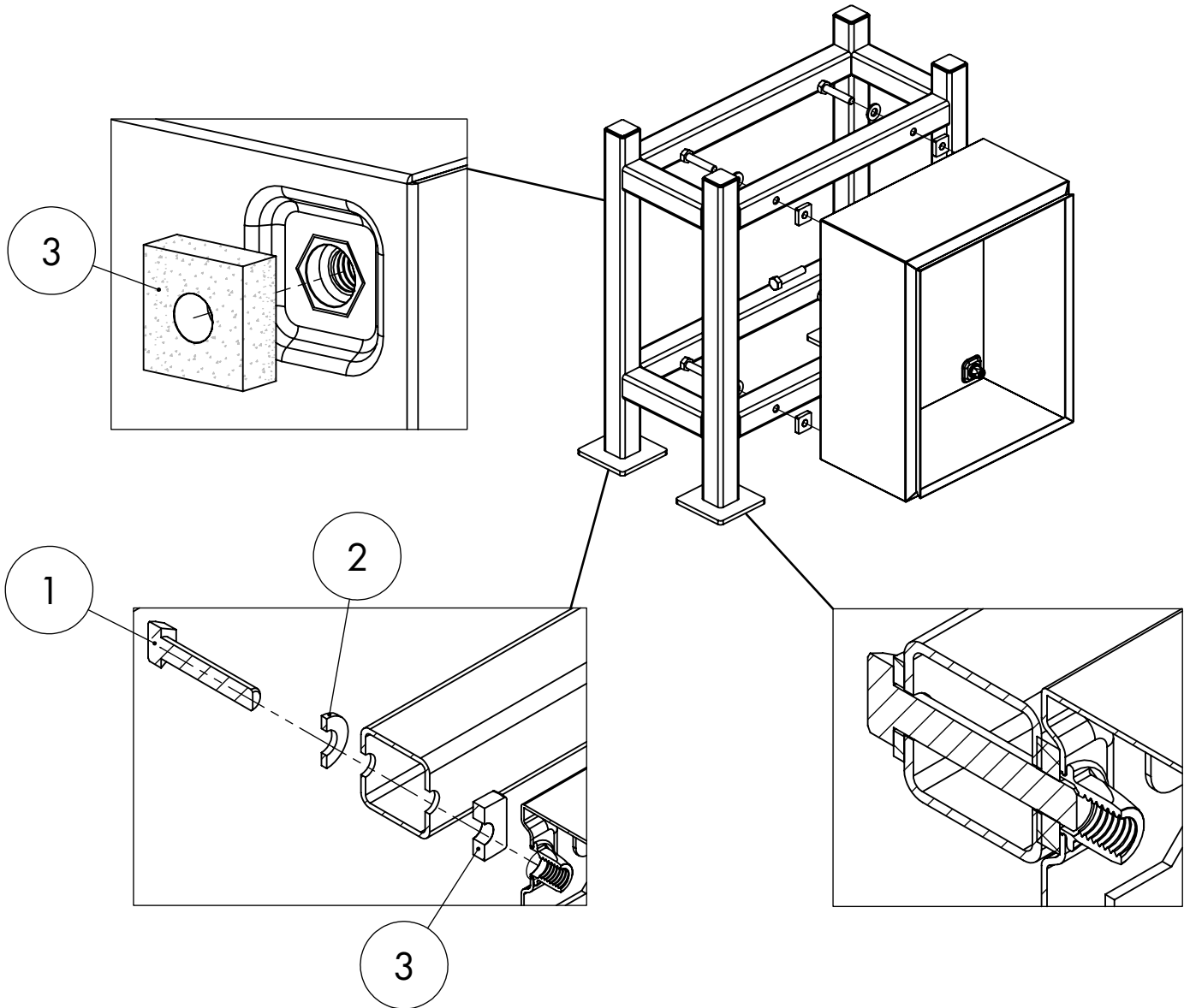

MONTAGE AUF PROFILSCHIENEN

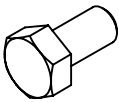
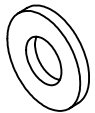

i **ERFORDERLICHE TEILE (Nicht im Lieferumfang enthalten!)**

Nr.			Stk.
1		M8	4
2		Unterlegscheibe M8	4
3		Selbstklebende Dichtung	4

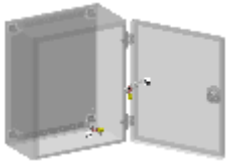

- 10mm
- 13mm

ERDUNG

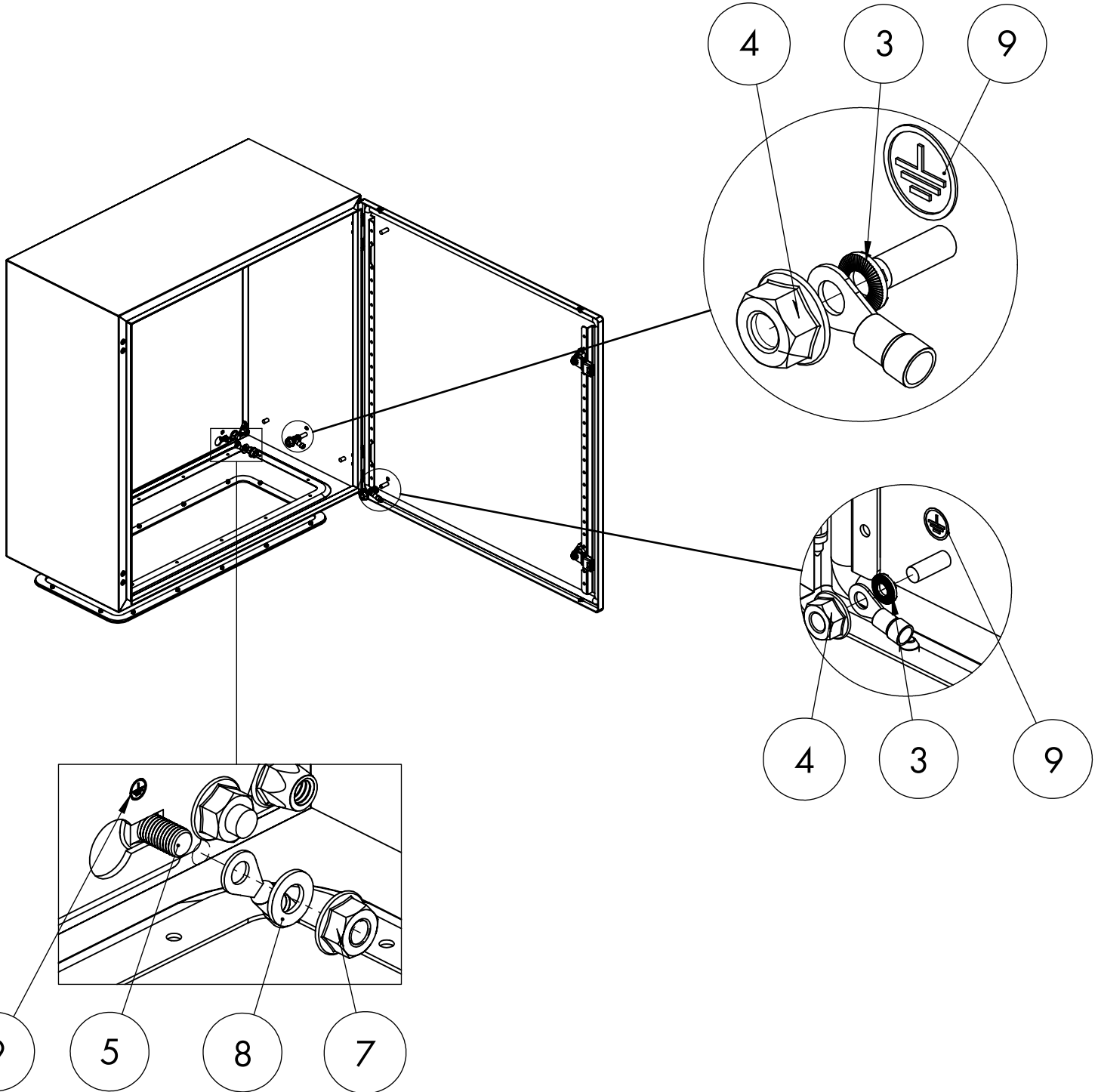

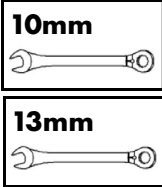
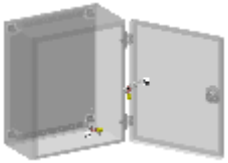

ERDUNG

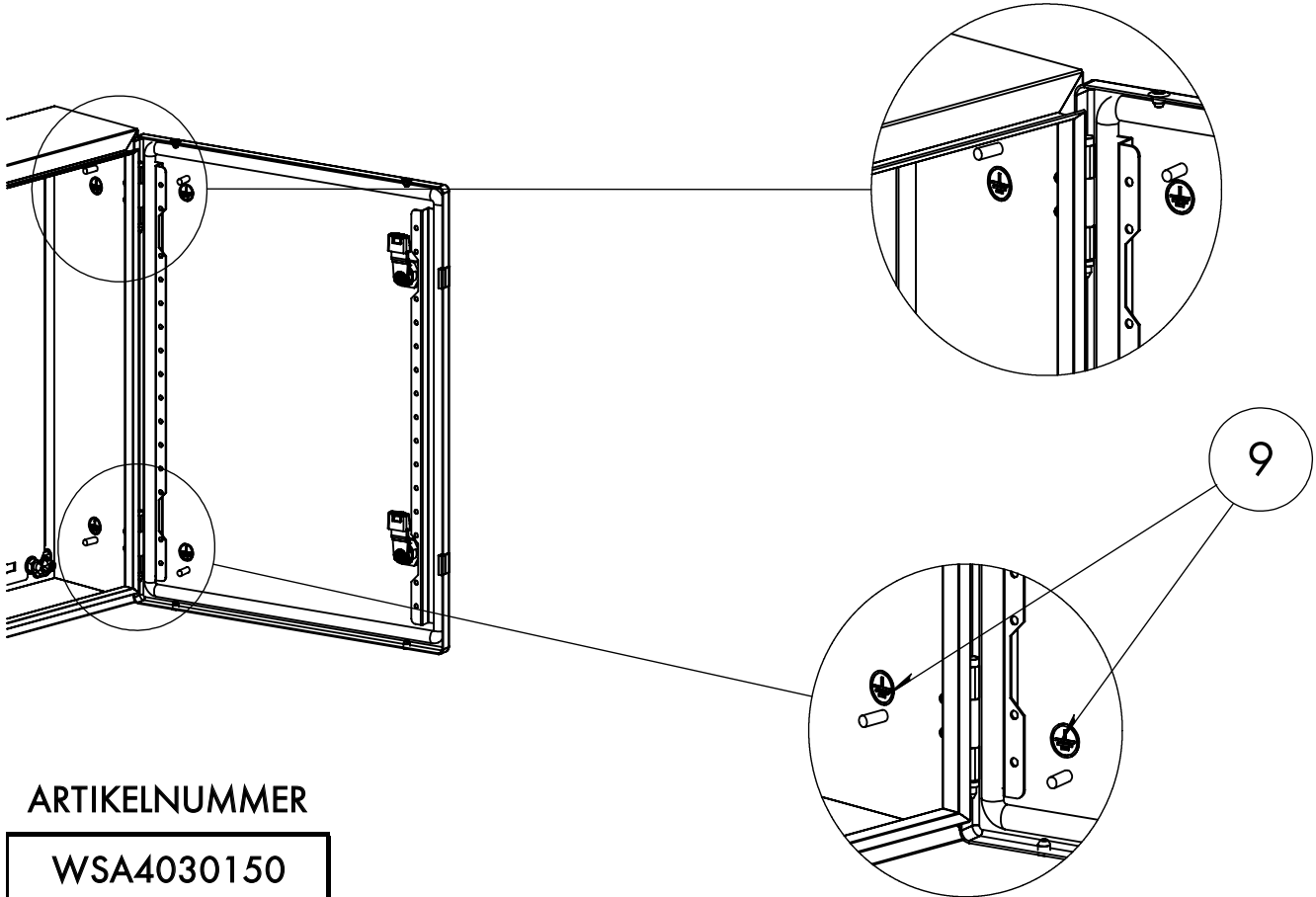

ARTIKELNUMMER

WSA4030150

WSA5040150

WSA6040150