

ARTIKELNUMMER

WKT2020150

WKT2520150

WKT2525150

Dieses Produkt ist ein Leergehäuse für Niederspannungs-Schaltgerätee Anwendungen mit einer maximalen Nennspannung von 1000V AC oder 1500V DC für den Innenbereich



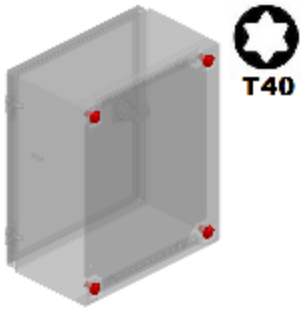



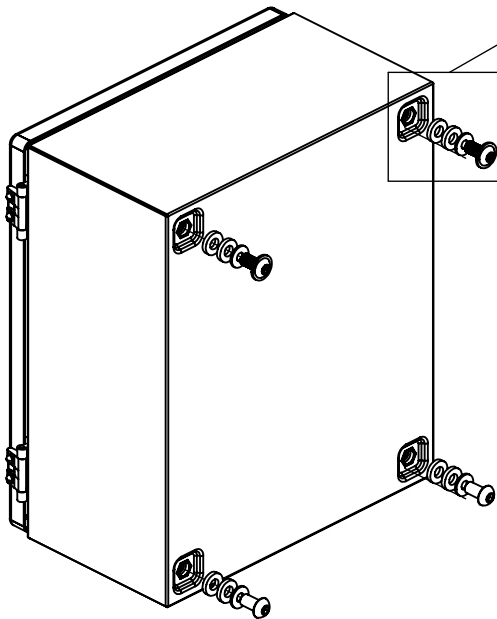
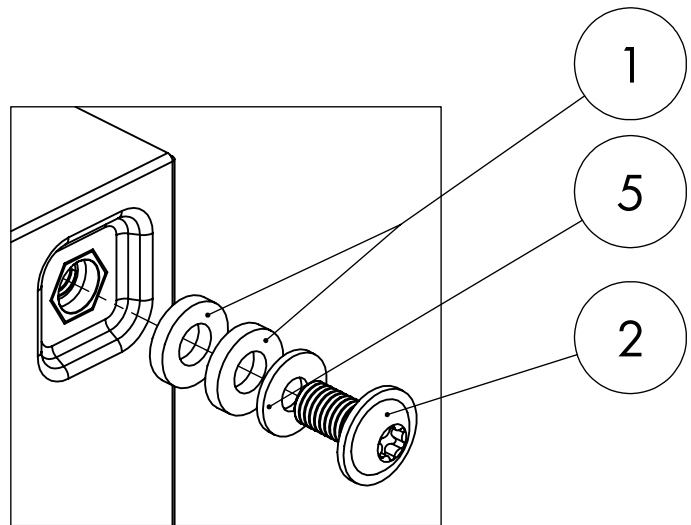





MONTAGE VON SCHRAUBEN UND DICHTUNGEN



MA = 10 + 1 Nm

LIEFERUMFANG

Nr.	Stk.	Nr.	Stk.				
1		Dichtung Ø16x8mm	8	6		M5x10mm	5
2		M8x16mm	4	7		M6	1
3		TYPE S Ø5.2	1	8		M6	1
4		Doppelbartschlüssel	1	9		Sticker	2
5		Unterlegscheibe M8	4				

MONTAGEPLATTENBEFESTIGUNG

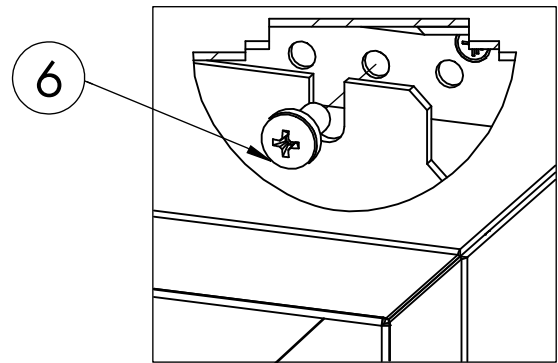
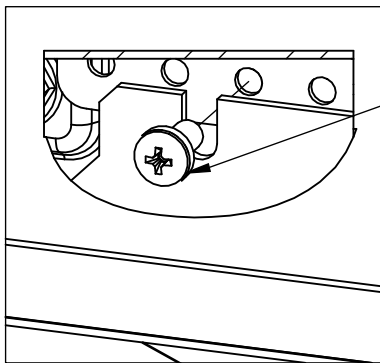
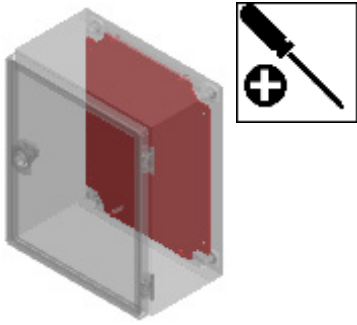

$MA = 5 + 1 \text{ Nm}$

$MA = 5 + 1 \text{ Nm}$

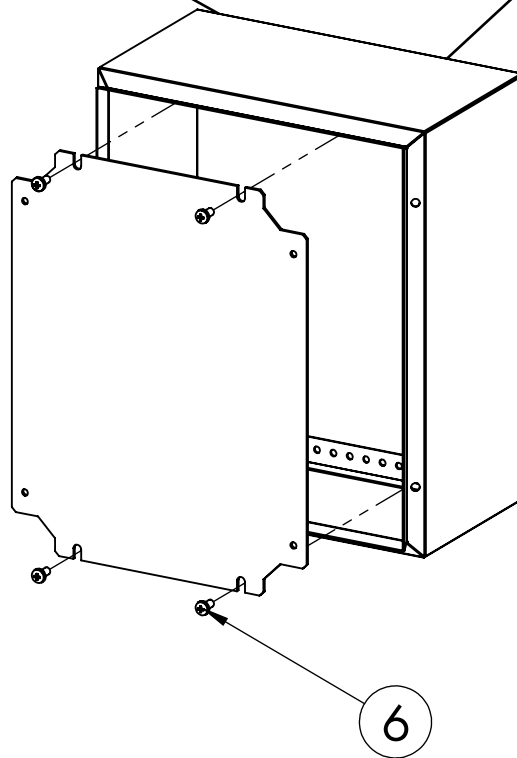

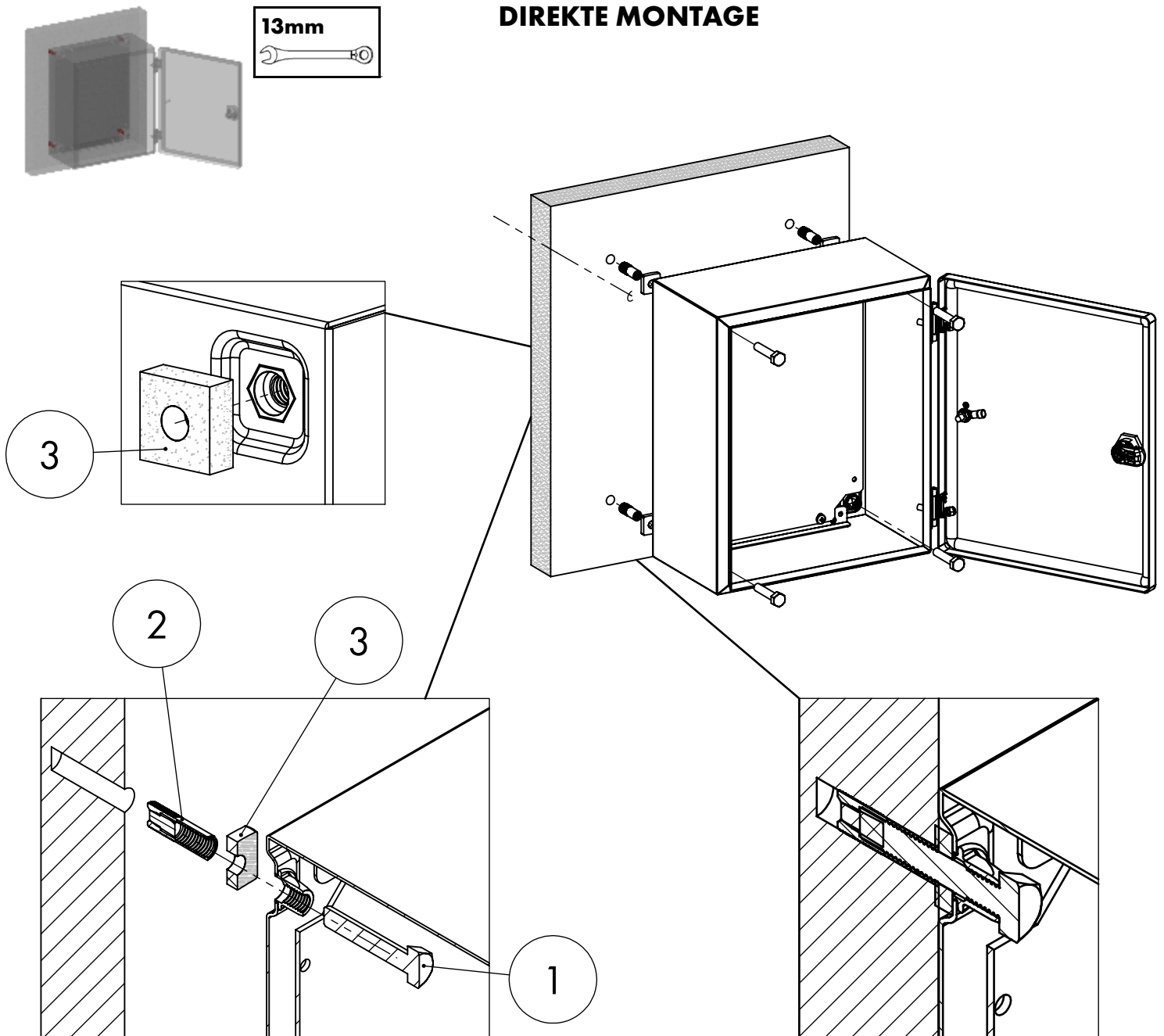

DIREKTE MONTAGE



MA = 10 + 1 Nm

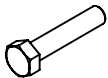

ERFORDERLICHE TEILE (Nicht im Lieferumfang enthalten!)

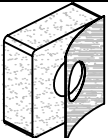

Nr.			Stk.
1		M8	4
2		Stahldübel M8	4
3		Selbstklebende Dichtung	4

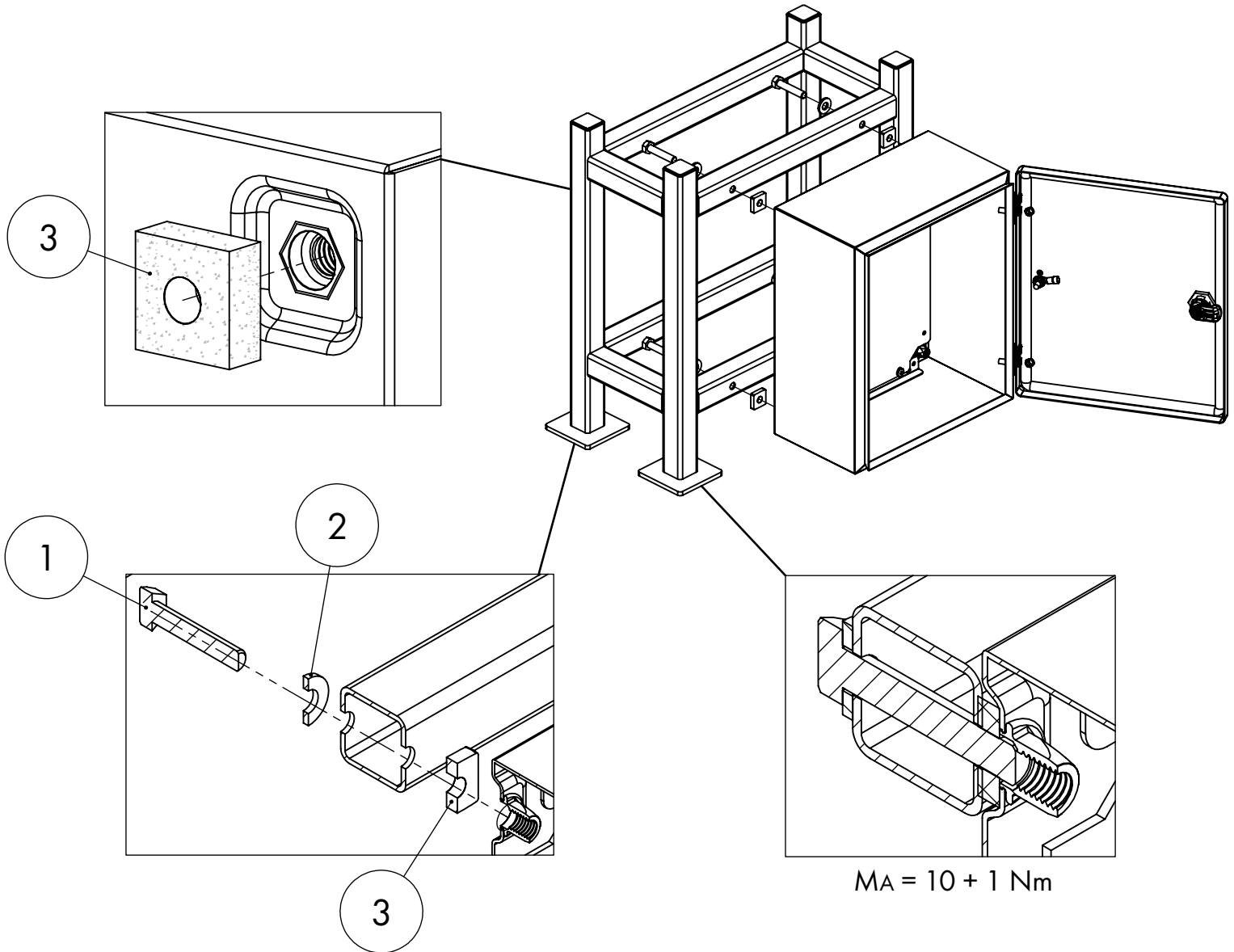
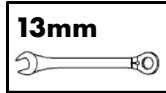
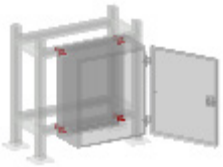
MONTAGE AUF PROFILSCHIENEN

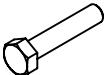

MA = 10 + 1 Nm

i **ERFORDERLICHE TEILE (Nicht im Lieferumfang enthalten!)**

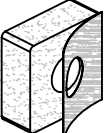
Nr.			Stk.
1		M8	4
2		Unterlegscheibe M8	4
3		Selbstklebende Dichtung	4

ERDUNG

