

CRITO®185 Power

Anschlussleiste 800 A / 1400 A
Connection rail 800 A / 1400 A
Regleta de conexión 800 A / 1400 A
bornier de raccordement 800 A / 1400 A
Modulo verticale di connessione 800 A / 1400 A
条形转接器 800 A / 1400 A

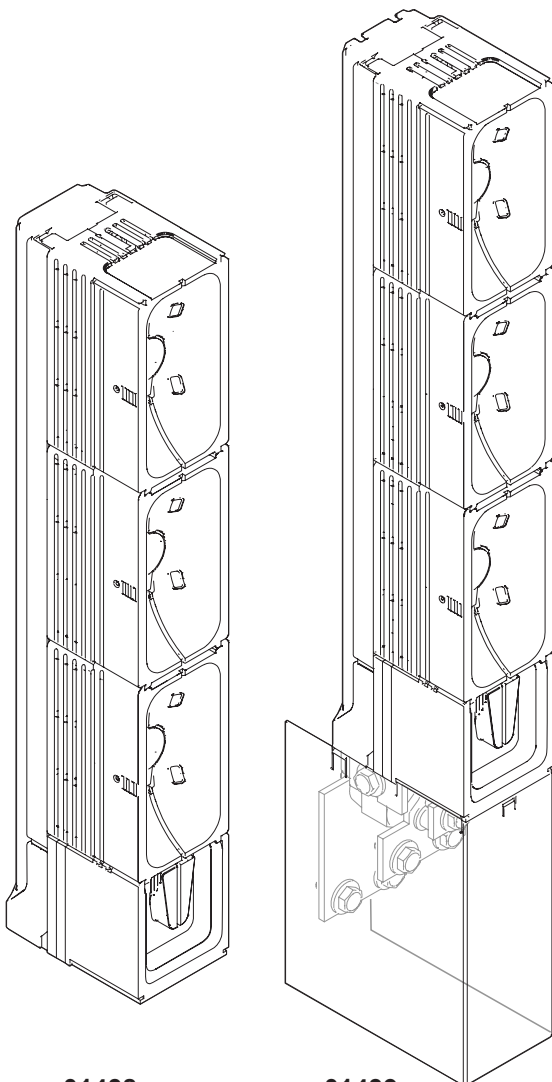

01438

01439

Achtung: Vor Installations- oder Servicearbeiten Stromversorgung unterbrechen, um Unfälle zu vermeiden. Die Geräte müssen in einem passenden Gehäuse eingebaut und gegen Verschmutzung geschützt werden. Inbetriebsetzung und Wartung nur durch Fachpersonal!

Attention: To prevent electrical shock, disconnect from power source before installing or servicing. Install in suitable enclosure. Keep free from contaminants. To be commissioned and maintained only by qualified personnel!

Atención: Con el objeto de evitar accidentes, hay que desconectar la alimentación eléctrica antes de realizar el montaje y la puesta en marcha. Debe instalarse en una caja o armario apropiado. Debe protegerse el producto de los ambientes agresivos. La puesta en marcha y el mantenimiento ha de hacerlo exclusivamente por personal especializado!

Attention: Avant le montage et la mise en service, couper l'alimentation secteur afin d'éviter tout accident. Prévoir une mise en coffret ou armoire appropriée, protéger le produit contre les environnements agressifs. Mise en service en entretien: seulement par du personnel spécialisé!

Attenzione: Per prevenire infortuni, togliere tensione prima dell'installazione o manutenzione. Installare in custodia idonea. Tenere lontano da contaminanti. Messa in servizio e manutenzione solo da personale specializzato!

注意: 安装前或检修前应切断电源，以防事故。开关应安装在适合的箱体，同时应做好防污染保护。只有专业人员才能做运行、维护、保养的工作。

1. Schienensystem

Busbar System

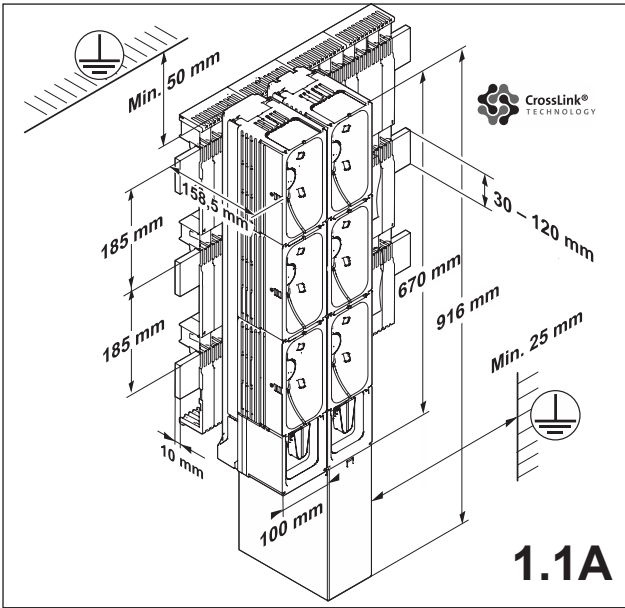

1.1A

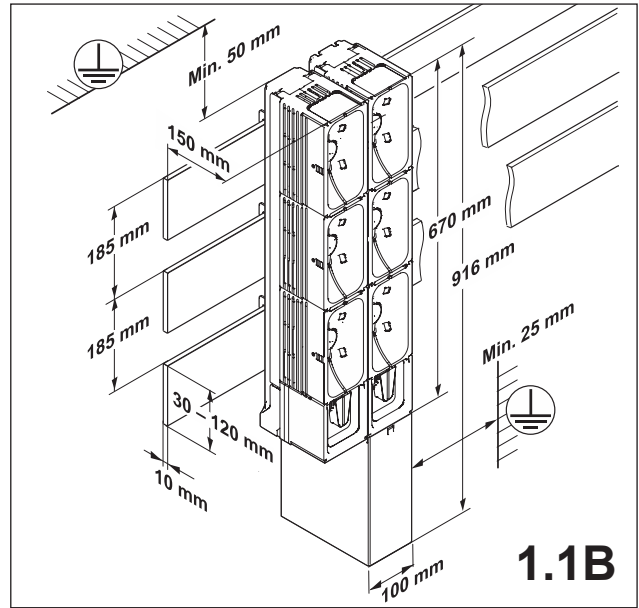

1.1B

2. 01 439 Montage CRITO®185 Power

01 439 Assembly CRITO®185 Power

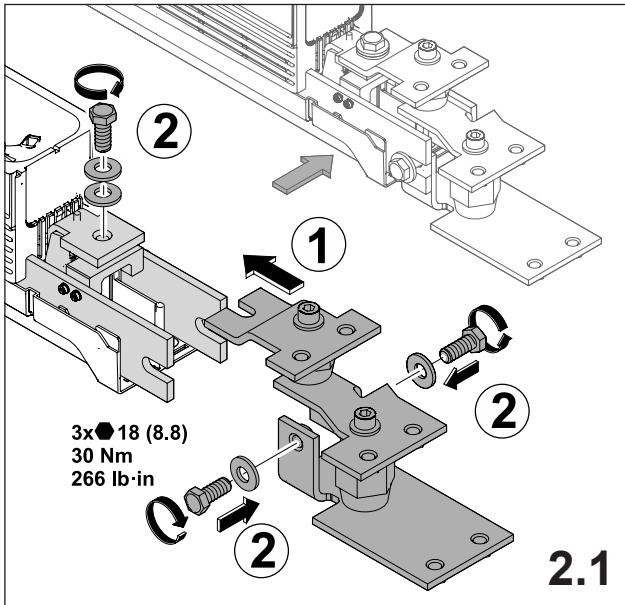

2.1

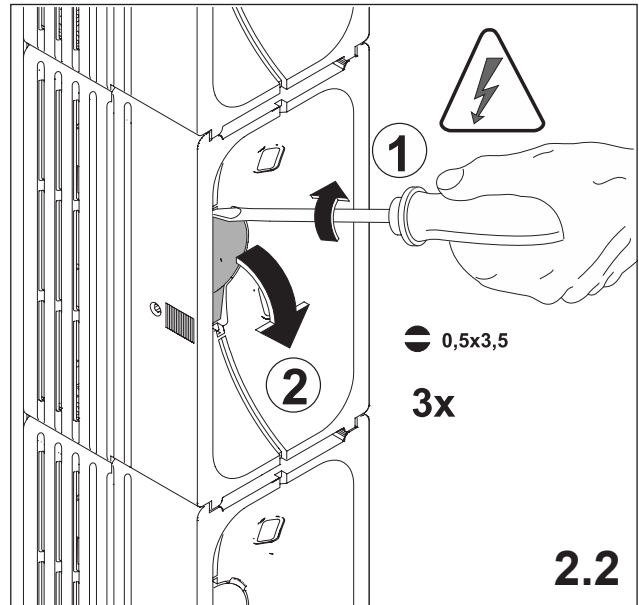

2.2

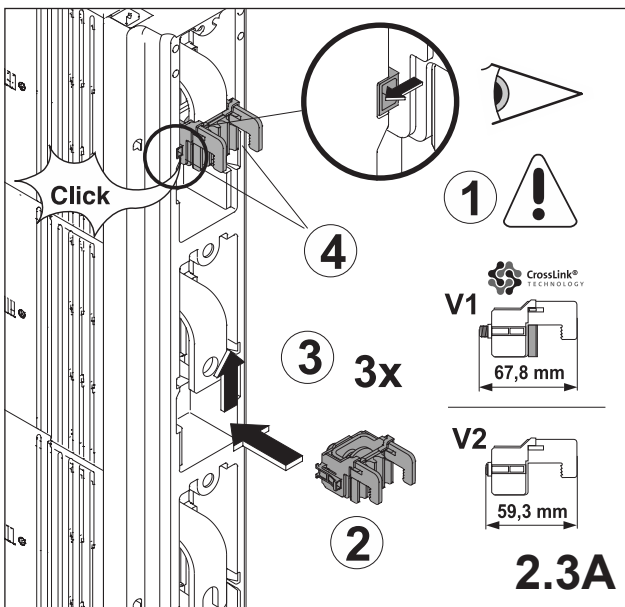

2.3A

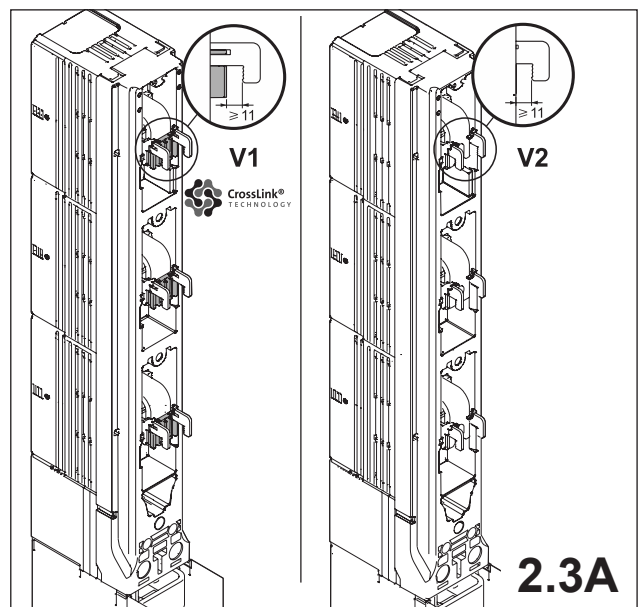

2.3A

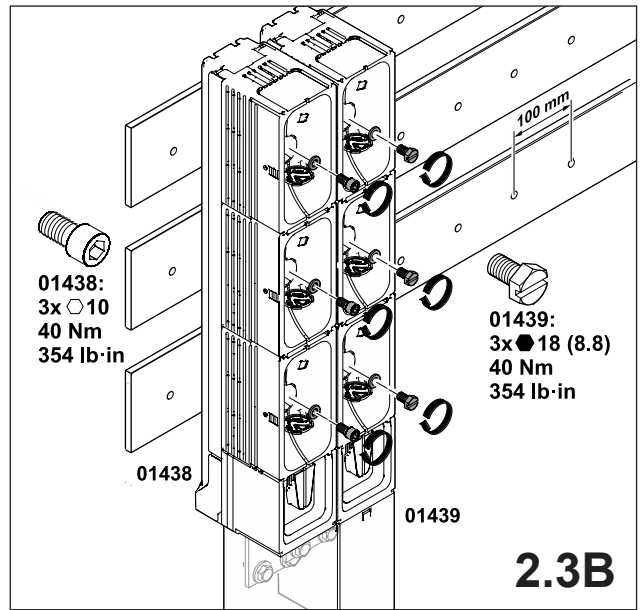
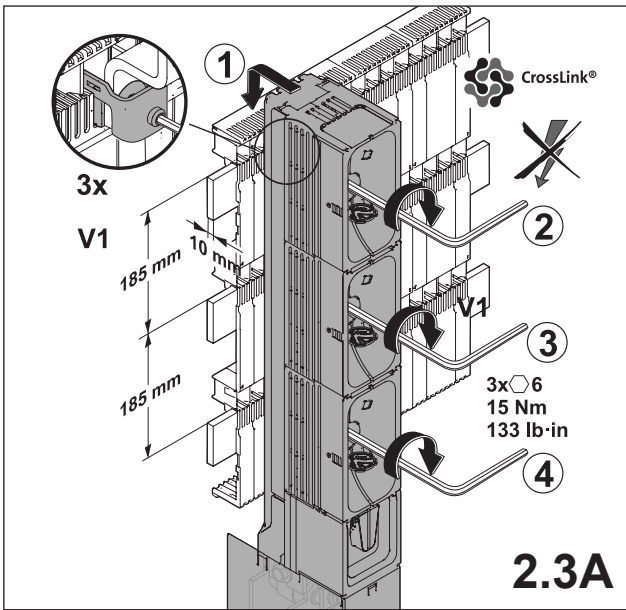

3. 01 438 Anschlüsse 01 438 Connections

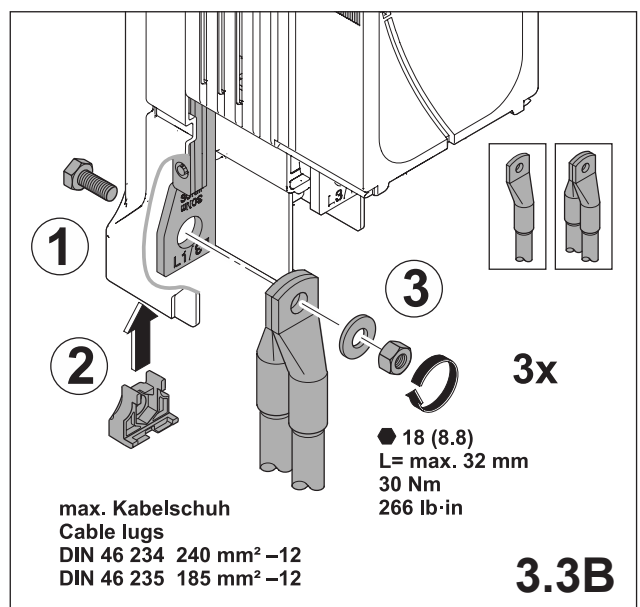
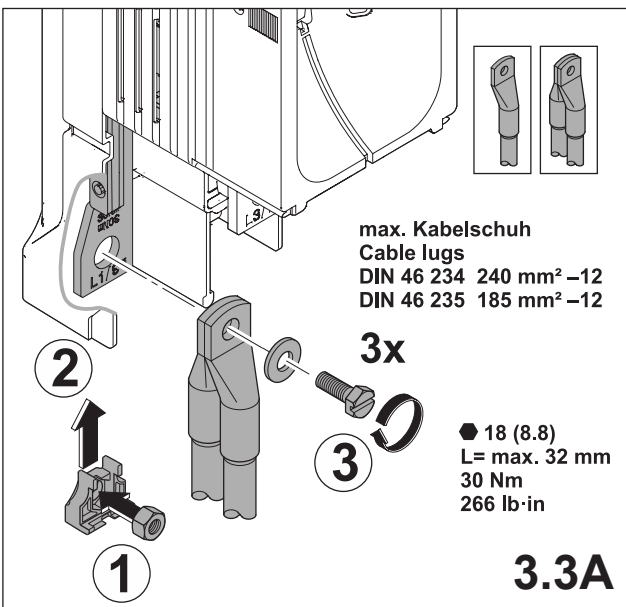
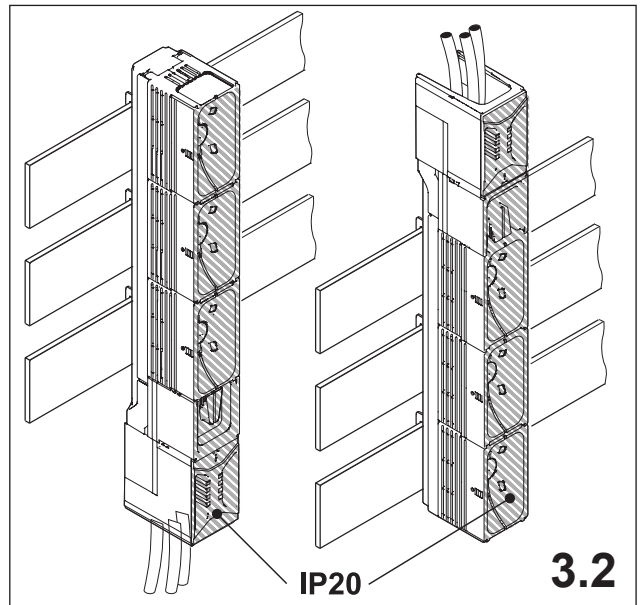
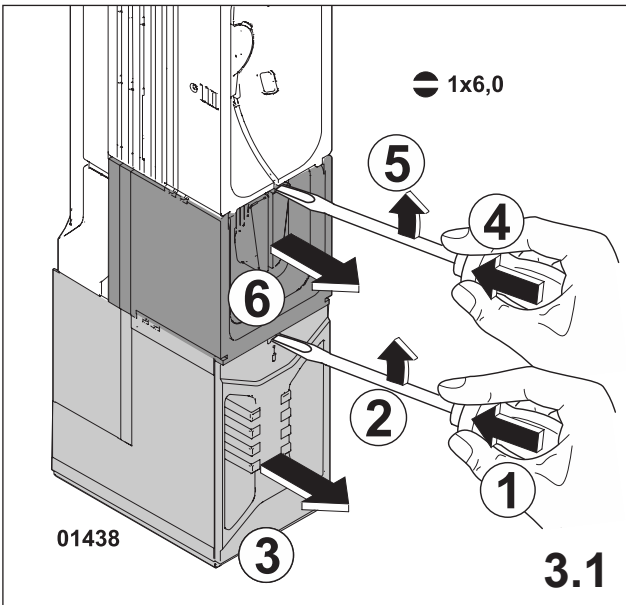

4. 01 439 Anschlüsse

01 439 Connections

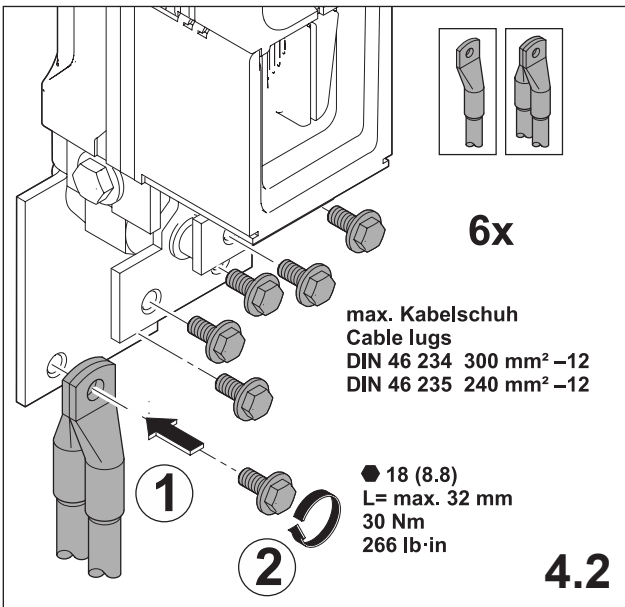
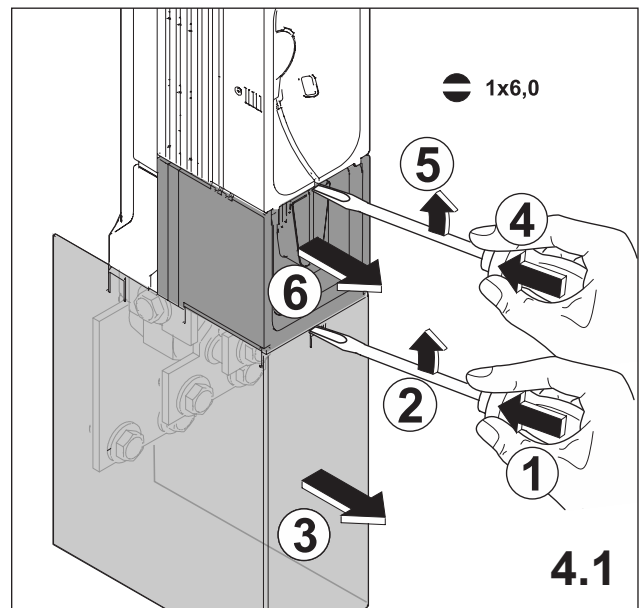
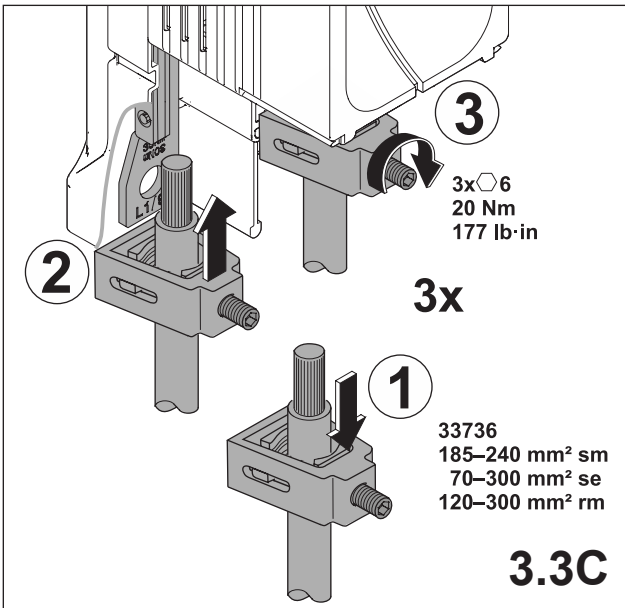

5. Anschluss oben

Connections up

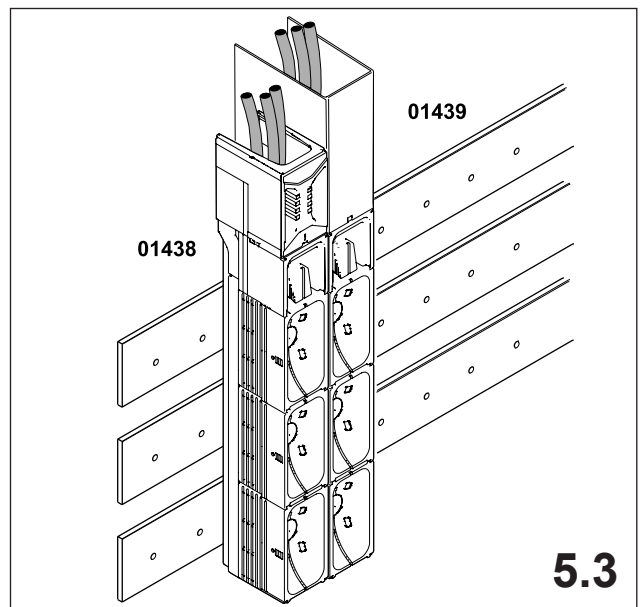
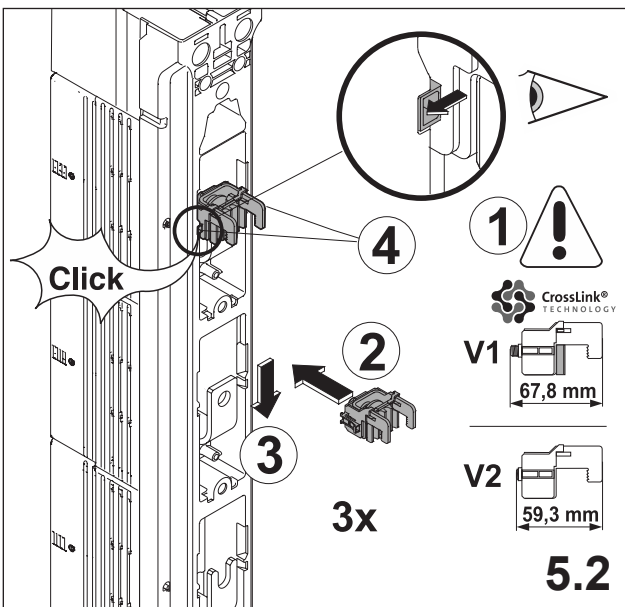
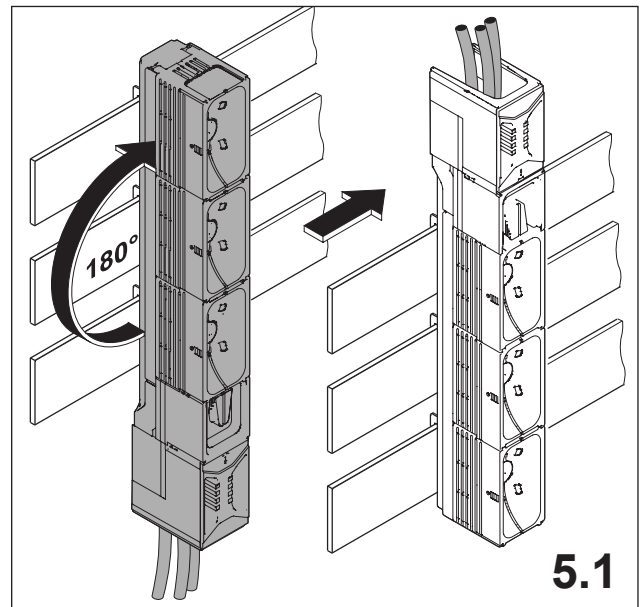

6. Plombieren der Anschlussleiste

Sealing of the connection rail

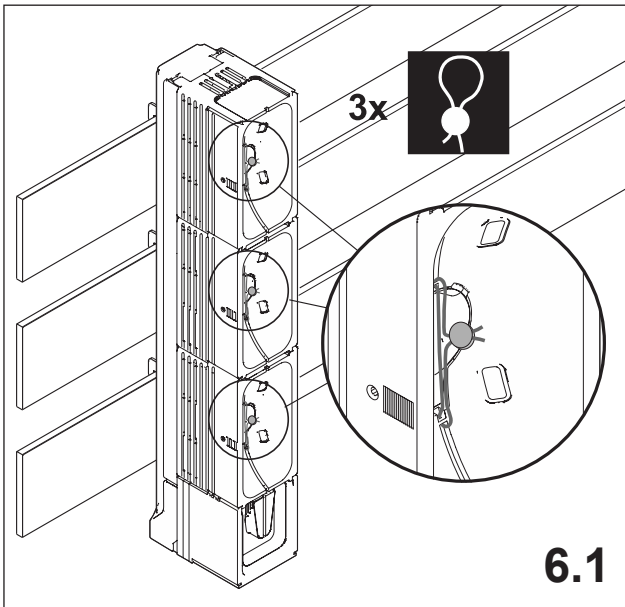

7. Stromwandler

current transformer

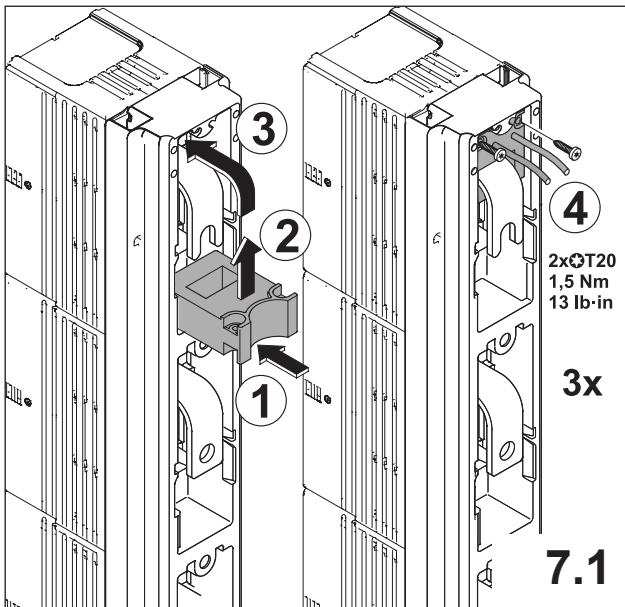

Notizen

A large grid of small dots for taking notes, consisting of 20 columns and 30 rows.